

## ESG VOLATILITY PREDICTION USING GARCH AND LSTM MODELS

AKSHAY KUMAR MISHRA <sup>1</sup>, RAHUL KUMAR <sup>2</sup>, DEBI PRASAD BAL <sup>3</sup>

### Abstract

This study aims to predict the ESG (environmental, social, and governance) return volatility based on ESG index data from 26 October 2017 and 31 March 2023 in the case of India. In this study, we utilized GARCH (Generalized Autoregressive Conditional Heteroskedasticity) and LSTM (Long Short-Term Memory) models for forecasting the return of ESG volatility and to evaluate the model's suitability for prediction. The study's findings demonstrate the GARCH effect inside the ESG return volatility data, indicating the occurrence of volatility in response to market fluctuations. This study provides insight concerning the suitability of models for volatility predictions. Moreover, based on the analysis of the return volatility of the ESG index, the GARCH model is more appropriate than the LSTM model.

**JEL classification:** C53, D53, G34, O13

**Keywords:** ESG Volatility, GARCH, LSTM model

Received: 22.08.2023

Accepted: 20.09.2023

### Cite this:

Mishra, A.K., Kumar, R. & Bal D.P. (2023) ESG Volatility Prediction Using GARCH and LSTM Models. *Financial Internet Quarterly* 19(4), pp. 97-114.

© 2023 Akshay Kumar Mishra et al., published by Sciencedo. This work is licensed under the Creative Commons Attribution-NonCommercial-NoDerivatives 3.0 License.

<sup>1</sup> Jaipuria Institute of Management, India, e-mail: akkykm@gmail.com, <https://orcid.org/0000-0003-1894-7393>.

<sup>2</sup> Birla Institute of Technology and Science–Pilani (BITS–Pilani), India, e-mail: kumar.rahul@pilani.bits-pilani.ac.in, <https://orcid.org/0009-0009-3875-221X>.

<sup>3</sup> Birla Institute of Technology and Science–Pilani (BITS–Pilani), India, e-mail: debiprasad.bal@gmail.com, <https://orcid.org/0000-0002-6124-9817>.

## INTRODUCTION

The inherent uncertainty of the financial market is among the most significant characteristics within this sector. A significant association exists between the level of risk associated with the underlying assets, and market volatility which can further serve as a valuable indicator for assessing both (Lim & Sek, 2013). Investors take on perilous risks due to the unpredictability of their holdings, making market volatility crucial (Bata & Molnár, 2018). A security's price is more likely to fluctuate widely if its volatility is high, while it may vary more slowly if its volatility is low (Nijs, 2013). As a result, investors' actions are influenced by volatility because of its connection to the uncertainty of the financial market (Dixit & Agrawal, 2019). Investors and scholars are usually inquisitive about which securities did well and how they could be protected from loss in the stock market. Investors evaluate a firm's financial and non-financial data to understand the processes through which the company makes profits for its stakeholders. Further, this evaluation facilitates more informed choices about investments in the stock market.

Although market uncertainty is a significant factor in making investment decisions, picking the right stocks remains paramount. Notably, Kaiser & Welters (2019) found that the practical application of ESG aspects is a critical part of ESG investments for momentum investors; by embracing ESG, they may lower portfolio risk. Given this newfound importance, researchers and professionals in the financial sector have increasingly focused on quantifying volatility (Bhowmik & Wang, 2020). Although several studies have been undertaken pertaining to forecasting volatility of the stock market (Alberg et al., 2008; Lin, 2018; Su et al., 2019; Fang et al., 2020; Salisu & Gupta, 2021), there has been relatively little work done on modelling volatility concerning ESG indices. For instance, Sabbaghi (2022) investigated the consequence of the news on the market volatility of ESG enterprises and discovered that bad news had a more profound effect on volatility than good news. The effective handling of ESG issues by a firm is commonly associated with positive outcomes in key performance indicators such as return on equity (ROE), return on assets (ROA), and share price (Whelan et al., 2022).

Therefore, we attempt to determine whether ESG stocks are characterized by a high degree of volatility, to enable all stakeholders to make informed decisions regarding the appropriate course of action to take when such stocks are included in their portfolios. The objective of this study is to evaluate the return volatility of the ESG index, with the purpose of investigating the existence and predictability of volatility within this sector. We have used the ESG index of the Bombay Stock Exchange (BSE) in India, which has been specifi-

cally developed to assess the level of exposure exhibited by securities that align with sustainable investment criteria for analysis. This study uses the GARCH (Generalized Autoregressive Conditional Heteroskedasticity) and LSTM (Long Short-Term Memory) models for the prediction of return ESG Volatility and evaluates the model's applicability for prediction. Both models are employed on the notion that one may use past data to make accurate forecasts. We have used BSE'S ESG Index data from October 26, 2017 to March 31, 2023. The duration for the data has been chosen for its (data) availability. This study makes several contributions to the existing body of literature. Firstly, the study's findings imply that the GARCH effect is present in the data for the ESG index, which further indicates that fluctuations in market volatility respond to changes in market conditions. Furthermore, we employed the RNN technique for our machine-learning models. Our analysis revealed that the GARCH (1,1) regression model was the most effective in predicting volatility. Based on the comparison of predicted values, the analysis shows that the GARCH model's predictions closely match the actual values. Our findings are novel and credible since we compared the two models we used.

This paper has been structured into different sections beginning with an introduction, the remaining portion includes the following, section two investigates the relevant literature on the research topic, section three provides a discussion of the method selected for the study. Results and subsequent discussion are described in section four, followed by the conclusion in section five.

## REVIEW OF LITERATURE

ESG (Environmental, Social, and Governance), comprises elements linked to the "environment", "social responsibility", and "governance" and encompasses the non-financial aspects of a company's performance (Yu & Xiao, 2022). Moreover, ESG's core tenet entails the recognition and measurement of aspects by corporations that demonstrate social responsibility, prioritize environmental sustainability, and maintain robust governance practices (Dalal & Thaker, 2019). Investor interest has increased in the incorporation of ESG factors within investment decision-making (Gangi et al., 2022).

Trade-off theory implies that corporations expect to make profits and maximize wealth, whereas legitimacy theories value ESG investments and disclosures as a way to make a profit (Behl et al., 2021). The global financial crisis raised business ethics, risk management, responsibility, and strategic stakeholder management concerns. This drew shareholder attention to ESG issues of the firms involved (Sultana et al., 2018). The availability of ESG information has increased and investors expect greater ESG disclosures (Espahbodi et al., 2019), notably

Li et al. (2018) found a positive association between the level of disclosure of ESG factors and the value of a firm. Investors worldwide are increasingly interested in the potential link connecting a company's ESG accomplishment, governance strength, and stock returns (Khan, 2019). According to Khalil & Nimmanunta (2021), investors now identify ESG measures as key considerations in managing risks, valuation, and adherence to legal requirements by companies. ESG factors have caught the attention of investors for two main reasons: ethical investment practices and managed portfolio performance (Broadstock et al., 2021). The importance of ESG stocks in an investor's portfolio is indisputable, owing to several factors, including risk, valuation, and portfolio performance. Moreover, ESG investment during situations of economic uncertainty is important since it represents an avenue for investments that are safer and carry less risk (Mousa et al., 2021). These studies indicate that the ESG factors, including disclosure, management, and performance, are vital for investors when selecting portfolio stocks. However, the area of ESG research is in a nascent stage; for example, ESG as a field of study is still in its early stages, owing to improved disclosure and availability of information (Zhou & Zhou, 2021). In addition, the review has enabled us to posit that investor interest in ESG companies is on the rise. Because of this, it is useful to investigate the volatility of the ESG index to discover more about the performance of these stocks over time. Significantly, Moalla and Dammak (2023) suggested that while investors consider ESG practices when investing, businesses should adopt a proactive standpoint to ESG to develop an ESG reputation and keep stock prices stable.

Several studies have utilized the time series model in forecasting the uncertainty of returns. Yong et al. (2021), investigated stock market return volatility in Malaysia and Singapore. Endri et al. (2021) explored stock price volatility in Indonesia during the pandemic using GARCH models. These models are developed to explain the variability patterns of time series data and are extremely effective at characterizing the volatility of financial data (Lin, 2018). Furthermore, advanced technology like artificial intelligence and deep learning procedures that have been widely utilized in wide domains have fewer constraints and superior feature extraction than conventional econometric models (Lin et al., 2022). Similarly, neural networks enhance error indicators of the best GARCH forecasts and further improve the projections and, thus the significance of the results (Kristjanpoller & Hernández, 2017). Moreover, Kim & Won (2018) utilized a hybrid model integrating LSTM (long short-term memory) and multiple GARCH and found that the former demonstrates competencies

in learning complex temporal patterns from time-series data, and as data volume expands, the model can learn the features to predict realized volatility, improving prediction accuracy. Similarly, Koo and Kim (2022) suggested a model that blends LSTM and GARCH networks to forecast market volatility and mitigate the volatility distribution's extreme bias. Since the semi-strong form of market efficiency and high noise make it challenging to predict financial time series, the LSTM network can get useful details out of noisy data (Zhou et al., 2018). Notably, because ESG features are prevalent in financial markets, researchers investigate the link connecting ESG characteristics to firm financial performance; nevertheless, investors' responses to information concerning ESG are less clear (Chen & Yang, 2020). However, the studies have explored the volatility of stock prices and stock indexes using GARCH and a deep learning model on ESG volatility, specifically with respect to an Indian perspective, has been little explored. Therefore, we propose a model to evaluate ESG volatility based on BSE's ESG index using deep learning methods (LSTM) and GARCH.

## DATA SOURCES AND METHODOLOGY

This paper is based on daily data of ESG between 26th October 2017 and 31 March 2023. In total, we have 1347 observations. The data was collected from the [www.bseindia.com](http://www.bseindia.com) website. We have used the logarithm of ESG (LESG) then we calculated the return of LESG (Ratio of the LESG at present period and one period lag of LESG multiplied by 100). In the next step, we have taken the volatility of return LESG (RVLESG) by using GARCH (1,1) model. The reason for measuring the return volatility of ESG is to predict it by using two methods using GARCH (1, 1) and the long short-term memory (LSTM) framework so that our results are robust and reliable. More specifically, we have the choice between machine learning and traditional regression models. The prima facie reason is the observed better performance of machine learning models regarding accuracy, precision, and recall compared to traditional regression models. The regression models require a priori specification of the functional form and variables included. Unless specified, regression models assume linear relationships. In this respect, the machine learning models are more flexible as they do not require any prior model specification. They can automatically detect complex linear and non-linear patterns to make predictions. Machine learning models also overcome the assumptions embedded in the regression models. Specifically, if the error terms are heteroskedastic and autocorrelated, then certain adjustments are required in the case of regression but the machine learning models are less sensitive to error structures and focus more on prediction accuracy. In the next step, we conducted the LSTM, a Recurrent Neural Network (RNN) type, and the GARCH model.

LSTM was devised to address the “exploding” and “vanishing” gradient concerns in the original RNN (Yu & Li, 2018) This is required since ESG volatility data includes long-term dependencies in the historical data. The RNN predicts future values by sequentially unrolling a unit network over past values using weights, biases, and feedback loop connections. It solves the vanishing gradient problem and has several other desirable qualities, which is why it was chosen for this study. For example, an LSTM network can account for temporal changes across time by keeping its state constant from iteration to iteration. Capturing temporal variations is essential for predicting future values for time series data. LSTM also accepts non-linear relationships, common in financial data, such as ESG volatility. To address non-linearity in time series data, LSTM employs non-linear activation functions such as tangent, sigmoid, hyperbolic, etc. Because of the variability in the factors influencing it, ESG data may suffer from variable length input sequences. As a result, LSTM is advantageous for another reason: it can accommodate variable length input. Aside from such technical reasons, we chose LSTM because of its proven accuracy in predicting factors in the financial market. And since ESG is a closely connected topic, we also want to assess LSTM’s effectiveness in this case. The literature review also does not provide research that forecasts ESG volatility explicitly using the LSTM network model. The quality of prediction from LSTM is affected by data preprocessing, network architecture, and hyperparameter tuning. Tuning hyperparameters alone requires multiple combinations (theoretically, there can be infinite combinations); therefore, including all of them is beyond the scope of this study. As a result, the objective of this piece is not to be exhaustive but rather to establish a foundation for identifying the most effective approach to forecasting ESG volatility. We will predict the return ESG volatility over the test data set using the LSTM and the GARCH model and judge the accuracy based on the root mean square value. Below we have depicted the working of the LSTM model.

The elongated green line situated at the uppermost part of the unit is referred to as the “cell state” and indicates “long-term memory”. Contrary to basic RNN, no weights and biases can directly modify the long-term memory in LSTM and thus avoid gradient vanishing/explosion. The pink line is referred to as the “hidden state”, and it is carrying “short-term memory” across the unrolled units in the series. However, the hidden state is directly connected to weights and biases; hence, the short-term memories can be modified directly. Long and short-term memory interacts in three stages to generate predictions, these three stages include “Forget gate”, “Input gate”, and “Output gate”. The forget gate is a crucial component that plays

a role in determining the proportion of long-term memory that is to be retained. The next stage is comprised of two blocks. The block situated on the right side of the diagram integrates the short-term memory and the input in order to generate the potential for long-term memory formation. The left block is responsible for determining the proportion of possible long-term memory that ought to be retained. This retained information is then added to the long-term memory that is exiting the forget gate. Consequently, the aggregate of memory that passes through the forget gate and the input gate becomes the newly formed long-term memory. Since the second stage updates the existing long-term memory, it is usually called the input gate. The final stage also consists of two blocks. The one situated on the right side generates a novel potential short-term memory by utilizing the recently acquired long-term memory. Conversely, the block situated on the left side determines the proportion of the potential short-term memory that will be retained. The output produced by the third stage is the new short-term memory, and since this stage represents the final output generated by the complete unit network, it is referred to as the output gate. At all three gates, the RNN uses an activation function to generate output. In simple words, the activation function is a mathematical function that converts x-axis coordinates into y-axis coordinates. Traditional LSTM uses sigmoid and tanh activation functions as gating functions and output functions respectively. Efforts have been made to search for novel activation functions which can replace the sigmoid and tanh activation functions to give more accurate results. One such example is the Combined hyperbolic sine function ( $y = \sinh(x) + \sinh^{-1}(x)$ ), which was explored using a differential evolution algorithm (DEA).

The basic RNN uses a single path for short-term and long-term memories, which is why the vanishing/exploding gradient occurs. If the gradient explodes, the predicted value is highly over-estimated, and if the gradient vanishes, then the predicted value is highly under-estimated. Hence it is tough to train the basic RNN to learn long-range dependencies. LSTM is different from basic RNN in the sense that it uses two different feedback loop connections for long and short-term memories to make predictions of future values. Compared to traditional RNN, the unit structure of LSTM is much more complicated as shown in Figure 1.

Figure 4 shows the unroll of unit LSTM to predict the value for variable Y in period  $t + 1$  using its values from periods  $t$ ,  $t - 1$ , and  $t - 2$ . The input at the first unit of LSTM is  $Y_{t - 2}$ . The forget gate updates the initial long-term memory to generate the new long-term memory, which in turn acts as the initial long-term memory for the second unit. Similarly, the input and output gate

generates the new short-term memory, which in turn acts as the initial short-term memory for the second unit. The same process is repeated in the second unit

and the third unit. The output generated out of the third unit is the predicted value for period  $t + 1$ .

Figure 1: Unroll of unit LSTM

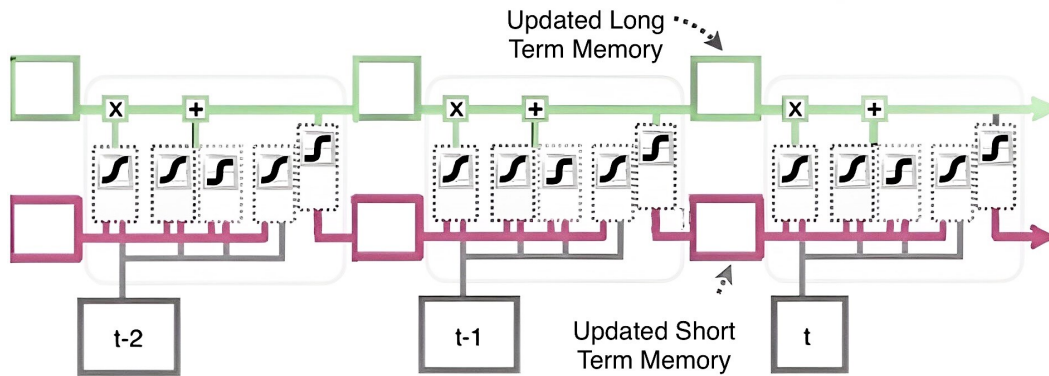

Source: Author's own work.

## RESULTS AND DISCUSSIONS

We predict the return volatility of LESG using two techniques: regression and machine learning. We employ GARCH methodology in regression, and in machine learning, we have used RNN's LSTM model. In the initial step, we provided the descriptive statistics, and the results are presented in Table 1. The result shows that the RVLESG index has very high variance compared to its transformation i.e. LESG, Return, and Return Volatility. However, the transformed variable like Return Volatility is highly asymmetrical as measured by the skew-

ness. ESG has a skewness of 0.38, whereas Return Volatility has a skewness of 7.46. Both ESG and Return Volatility have kurtosis values far from that of normal distribution. The skewness and kurtosis values suggest that none of the variables are normally distributed. And this is the reason why we have used the GARCH regression model to predict the Return Volatility. In the next stage, we have presented the results of the GARCH model in Table 2. The results from Table 2 show the output from LSTM, using different combinations of hyper-parameters.

Table 1: Descriptive statistics

Variable	Obs	Mean	Std. dev.	Min	Max	Skewness	Kurtosis
ESG	1,347	218.672200	54.488320	119.630000	315.840000	0.38	1.50
LESG	1,347	2.326597	0.106496	2.077840	2.499467	0.24	1.51
Return	1,346	0.018420	0.524037	-5.910230	3.598482	-1.44	22.04
RVLESG	1,345	0.268383	0.535019	0.071007	6.701008	7.46	66.83

Notes:

ESG is 'Environment social and governance' index.

LESG is Natural logarithm of ESG.

RVLESG is the volatility of Return.

Source: Author's own work.

The results in Table 2 suggest that one percentage change of one period lag in return volatility of LESG significantly influences the present period of return volatility of LESG at about 0.05 percentage level. It implies that the previous period's change positively responds to the current period. We have checked all other residual diagnostic tests such as correlogram, heteroscedasticity, and autocorrelation test. It satisfies all the properties of a classical regression model. Once we

had stabilized the mean equation, we conducted the GARCH model. The equation for the GARCH (1,1) variance model indicates a constant value of 0.00646. The ARCH coefficient of 0.108, which represents the volatility response to market movements, indicates a good correlation between market movement and volatility. The coefficient GARCH of 0.865 shows more intensive variance.

The estimated GARCH equation is:

$$RVLESG = 0.00646 + 0.107961 * (u_{t-1})^2 + 0.864839 * RVLESG_{t-1} \quad (1)$$

Where RVLESG is the predicted value of the dependent variable,  $u_{t-1}$  is displaying the first lag of the

error term from the AR(1) equation and  $RVLESG_{t-1}$  is the first lag of the dependent variable. The error term is estimated using the AR(1) estimates from Table 1. The AR(1) equation is:

$$Return_t = 0.033015 + 0.56237 * Return_{t-1} \quad (2)$$

**Table 2: Estimated coefficient for RVLESG using GARCH**

Mean Equation		
Variables	Coefficient	p-value
C	0.033015	0.0037
AR(1)	0.056237	0.0568
Variance Equation		
C	0.006460	0.0002
Resid(-1)^2	0.107961	0.0000
GARCH(-1)	0.864839	0.0000
R-squared	-0.007760	
Adjusted R-squared	-0.008510	
S.E. of regression	0.526450	
Akaike info criterion	1.131637	
Schwarz criterion	1.150983	
Hannan-Quinn criterion	1.138883	

Source: Author's own work.

**Table 3: RMSE for the different combinations of hyperparameters in LSTM**

epochs	Activation function	
	ReLU	Default
10	0.0280	0.098
20	0.0230	11.370
30	0.2190	0.385
40	0.0316	0.040
50	0.4520	0.106
60	0.0980	0.141

Source: Author's own work.

Using equation 2, we estimate the predicted values for Return, and then using equation 3, we calculate the value for the error term  $u_t$  which is equal to the actual return minus the estimated return.

$$U_t = actual\ return - Return_t \quad (3)$$

Further, using equation 3 we calculate the square of the error term, whose first lag is to be used as the independent variable in the GARCH equation. Based on the RMSE criterion, we should choose the GARCH model over the LSTM models for predicting volatility. The RMSE of GARCH is equal to 0.011355, which is much less than the RMSE of all the LSTM variants shown in Table 2. In Figures 2 to 14 (Appendix) the predicted values of RVLESG volatility from both models are compared with the actual values in the test set of the data. Predicted values in Figures 3 to 14 were estimated us-

ing the LSTM model and differ only in terms of the type of activation function. In Figures 3 to 8 ReLU activation function is used whereas in Figures 9 to 14 the default activation function is used. The values from the LSTM vary widely from the actual values in the test set whereas, on the other hand, the GARCH predicted values move very close to the actual observed values. So, for variables like volatility, where the dependency can't be traced back to a very long past, we should refrain from using LSTM and instead apply the appropriate traditional regression models.

The aforementioned results are obviously at odds with those discovered in the related field of financial markets. This investigation will need to be more comprehensive, as was previously stated. Only a small subset of possible parameter tuning combinations has been investigated. Since ESG has such profound practi-

cal ramifications, we defer to future research in determining which alternative combinations of parameters yield the most accurate prognostic model. The practical implication of predicting return ESG volatility can be understood with the help of two examples stated below.

ESG return volatility can indicate the shift in the company's environmental profile and signal potential future risk. Take the case of BP's water Deepwater Horizon oil spill (Pallardy, 2023). This catastrophic event (2010) implied environmental risk management failure. The intensity of the failure can be seen from the fact that approximately 65 billion dollars were spent for cleanup and settlement purposes. The reputational damage was such that the company lost 50% of its share price value within a few months of the incident. This implies that investors lost 50% of their money in BP Deepwater horizon stocks/shares. Here, tracking the ESG volatility or the ESG itself could have helped investors anticipate the environmental risks, potentially helping them mitigate some of their financial losses.

Accurately predicting ESG volatility can guide companies in strategic planning to gain a competitive advantage over their competitors and peers in the light of constantly evolving regulations, societal expectations, and environmental constraints. As a real-world example, take the case of Orsted (Scott, 2021), a Danish energy company that once was a coal-intensive public utility company. This company strategically went under radical transformation to become the world's most sustainable energy company (Corporate Knights' 2020 Global 100 index). The strategic planning was in anticipation of stricter environmental regulation and increasing biasedness of public sentiments towards renewable energy.

The foregoing two real-world examples emphasize the significance of precise ESG volatility forecasting. We observe that LSTM, which showed promise in the financial market domain, may be different from the silver bullet in the related domain. This article may be considered the first mile on the road to search for more sophisticated models with better predictive power.

## CONCLUSIONS

A policy paradigm change towards ESG is vital in light of the current environmental crisis and the pervasive social and economic disparities in the Indian economy. This change is not just about doing the right thing ethically. It's also an essential aspect of sound financial strategy that can lead to more opportunities and less long-term danger. The future can be made more secure through ESG-focused investing. Therefore, it is essential to determine ESG and ESG return volatility values and methods that help attract global investment to India. In this study, we compared results from machine learning

to those from regression and found that the latter produced more reliable outcomes. In this study, we used the RNN technique for our machine-learning models and the GARCH (1,1) model, which exhibited the highest efficacy as a regression model. RNNs are characterized by their various configuration options. Parameters were adjusted in several iterations. Furthermore, this study offers the following significant contributions to the current body of literature. First, an assessment was made to determine the appropriateness of the model for forecasting volatility utilizing the ESG index data procured from the Bombay Stock Exchange (BSE). Previous research has indicated that the utilization of machine learning methodologies, particularly long-short-term memory (LSTM), has the potential to improve the accuracy of outcomes. However, different results have been observed. Considering this, we recommend it should not be used for shorter periods of time. Second, the applicability of the GARCH (1,1) model is considered to be best-suitable for predicting volatility in this connection. The fact that the GARCH model can be applied for shorter time periods was emphasized, as shown by the analysis. This finding was supported by the evidence. Considering this, we recommend using appropriate classical regression models rather than LSTM for the purpose of predicting volatility. Finally, the findings of the GARCH (1,1) model indicate the existence of an ARCH effect in the dataset. Consequently, the response of volatility to market fluctuations exhibits positive reactions with the intensity of market movements. Additionally, the study reveals that a one per cent change in the lagged return volatility of ESG significantly impacts the current period of return volatility of ESG, with a magnitude of approximately 0.05 percentage level.

This study offers implications for investors, policymakers and researchers concerning the presence of volatility in ESG investing particularly in shares. The findings of this study can be used by investors making investment decisions in selecting ESG or other stocks in their portfolios. The present study exclusively relies on data from the ESG index, skipping the assessment of additional criteria like expenditure, disclosure, behavioral aspects, and other microeconomic factors. Furthermore, the study provides a preliminary investigation and does not incorporate additional methodologies in machine learning. Consequently, this composition enables scholars to explore diverse methodologies and environments. The formulation of such methodologies would assist policymakers in cultivating an environment where economic actors perceive ESG not solely as a regulatory impediment but as a tactical tool capable of producing benefits for them.

## REFERENCES

- Alberg, D., Shalit, H. & Yosef, R. (2008). Estimating stock market volatility using asymmetric GARCH models. *Applied Financial Economics*, 18(15), 1201–1208, <https://doi.org/10.1080/09603100701604225>.
- Bašta, M. & Molnár, P. (2018). Oil market volatility and stock market volatility. *Finance Research Letters*, 26, 204–214, <https://doi.org/10.1016/j.frl.2018.02.001>.
- Behl, A., Kumari, P.S.R., Makhija, H. & Sharma, D. (2021). Exploring the relationship of ESG score and firm value using cross-lagged panel analyses: case of the Indian energy sector. *Annals of Operations Research*, 313(1), 231–256, <https://doi.org/10.1007/s10479-021-04189-8>.
- Bhowmik, R. & Wang, S. (2020). Stock Market Volatility and Return Analysis: A Systematic Literature Review. *Entropy*, 22(5), 522, <https://doi.org/10.3390/e22050522>.
- Broadstock, D.C., Chan, K., Cheng, L.T. & Wang, X. (2021). The role of ESG performance during times of financial crisis: Evidence from COVID-19 in China. *Finance Research Letters*, 38, 101716, <https://doi.org/10.1016/j.frl.2020.101716>.
- Chen, H.Y. & Yang, S.S. (2020). Do Investors exaggerate corporate ESG information? Evidence of the ESG momentum effect in the Taiwanese market. *Pacific-Basin Finance Journal*, 63, 101407, <https://doi.org/10.1016/j.pacfin.2020.101407>.
- Dalal, K.K. & Thaker, N. (2019). ESG and corporate financial performance: A panel study of Indian companies. *IUP Journal of Corporate Governance*, 18(1), 44-59.
- Dixit, J.K. & Agrawal, V. (2019). Foresight for stock market volatility – a study in the Indian perspective. *Foresight*, 22(1), 1–13, <https://doi.org/10.1108/fs-05-2019-0040>.
- Endri, E., Aipama, W., Razak, A., Sari, L. & Septiano, R. (2021). Stock price volatility during the COVID-19 pandemic: The GARCH model. *Investment Management and Financial Innovations*, 18(4), 12–20, [https://doi.org/10.21511/imfi.18\(4\).2021.02](https://doi.org/10.21511/imfi.18(4).2021.02).
- Espahbodi, L., Espahbodi, R., Juma, N. & Westbrook, A. (2019). Sustainability priorities, corporate strategy, and investor behavior. *Review of Financial Economics*, 37(1), 149–167, <https://doi.org/10.1002/rfe.1052>.
- Fang, T., Lee, T.H. & Su, Z. (2020). Predicting the long-term stock market volatility: A GARCH-MIDAS model with variable selection. *Journal of Empirical Finance*, 58, 36–49, <https://doi.org/10.1016/j.jempfin.2020.05.007>.
- Gangi, F., Varrone, N., Daniele, L.M. & Coscia, M. (2022). Mainstreaming socially responsible investment: Do environmental, social and governance ratings of investment funds converge? *Journal of Cleaner Production*, 353, 131684, <https://doi.org/10.1016/j.jclepro.2022.131684>.
- Kaiser, L. & Welters, J. (2019). Risk-mitigating effect of ESG on momentum portfolios. *The Journal of Risk Finance*, 20(5), 542–555, <https://doi.org/10.1108/jrf-05-2019-0075>.
- Khalil, M.A. & Nimmanunta, K. (2023). Conventional versus green investments: Advancing innovation for better financial and environmental prospects. *Journal of Sustainable Finance & Investment*, 13(3), 1153-1180, <https://doi.org/10.1080/20430795.2021.1952822>.
- Khan, M. (2019). Corporate Governance, ESG, and Stock Returns around the World. *Financial Analysts Journal*, 75(4), 103–123, <https://doi.org/10.1080/0015198x.2019.1654299>.
- Kim, H.Y. & Won, C.H. (2018). Forecasting the volatility of stock price index: A hybrid model integrating LSTM with multiple GARCH-type models. *Expert Systems With Applications*, 103, 25–37, <https://doi.org/10.1016/j.eswa.2018.03.002>.

- Koo, E. & Kim, G. (2022). A Hybrid Prediction Model Integrating GARCH Models With a Distribution Manipulation Strategy Based on LSTM Networks for Stock Market Volatility. *IEEE Access*, 10, 34743–34754, <https://doi.org/10.1109/access.2022.3163723>.
- Kristjanpoller, R.W. & Hernández P.E. (2017). Volatility of main metals forecasted by a hybrid ANN-GARCH model with regressors. *Expert Systems With Applications*, 84, 290–300, <https://doi.org/10.1016/j.eswa.2017.05.024>.
- Li, Y., Gong, M., Zhang, X.Y. & Koh, L. (2018). The impact of environmental, social, and governance disclosure on firm value: The role of CEO power. *The British Accounting Review*, 50(1), 60–75, <https://doi.org/10.1016/j.bar.2017.09.007>.
- Lim, C.M. & Sek, S.K. (2013). Comparing the Performances of GARCH-type Models in Capturing the Stock Market Volatility in Malaysia. *Procedia Economics and Finance*, 5, 478–487, [https://doi.org/10.1016/s2212-5671\(13\)00056-7](https://doi.org/10.1016/s2212-5671(13)00056-7).
- Lin, Y., Lin, Z., Liao, Y., Li, Y., Xu, J. & Yan, Y. (2022). Forecasting the realized volatility of stock price index: A hybrid model integrating CEEMDAN and LSTM. *Expert Systems With Applications*, 206, 117736, <https://doi.org/10.1016/j.eswa.2022.117736>.
- Lin, Z. (2018). Modelling and forecasting the stock market volatility of SSE Composite Index using GARCH models. *Future Generation Computer Systems*, 79, 960–972, <https://doi.org/10.1016/j.future.2017.08.033>.
- Moalla, M. & Dammak, S. (2023). Corporate ESG performance as good insurance in times of crisis: lessons from US stock market during COVID-19 pandemic, *Journal of Global Responsibility*, 14(4), 381-402, <https://doi.org/10.1108/jgr-07-2022-0061>.
- Mousa, M., Saleem, A. & Sági, J. (2021). Are ESG Shares a Safe Haven during COVID-19? Evidence from the Arab Region. *Sustainability*, 14(1), 208-226, <https://doi.org/10.3390/su14010208>.
- Yong, J.N.C., Ziaei, S.M. & Szulczyk, K.R. (2021). The impact of COVID-19 pandemic on stock market return volatility: Evidence from Malaysia and Singapore. *Asian Economic and Financial Review*, 11(3), 191, <https://doi.org/10.18488/journal.aefr.2021.113.191.204>.
- Nijs, L. (2013). *Mezzanine Financing: Tools, Applications and Total Performance*. John Wiley & Sons, Hoboken.
- Pallardy, R. (2023). Deepwater Horizon oil spill | Summary, Effects, Cause, Clean Up, & Facts. *Encyclopedia Britannica*, Chicago, <https://www.britannica.com/event/Deepwater-Horizon-oil-spill>.
- Sabbaghi, O. (2022). The impact of news on the volatility of ESG firms. *Global Finance Journal*, 51, 100570, <https://doi.org/10.1016/j.gfj.2020.100570>.
- Salisu, A.A. & Gupta, R. (2021). Oil shocks and stock market volatility of the BRICS: A GARCH-MIDAS approach. *Global Finance Journal*, 48, 100546, <https://doi.org/10.1016/j.gfj.2020.100546>.
- Scott, M. (2021). The Global 100 progress report. *Corporate Knights*, <https://www.corporateknights.com/rankings/global-100-rankings/2020-global-100-rankings/global-100-progress-report-2/> (Accessed: 22.08.2023).
- Su, Z., Fang, T. & Yin, L. (2019). Understanding stock market volatility: What is the role of U.S. uncertainty? *The North American Journal of Economics and Finance*, 48, 582–590, <https://doi.org/10.1016/j.najef.2018.07.014>.
- Sultana, S., Zulkifli, N. & Zainal, D. (2018). Environmental, Social and Governance (ESG) and Investment Decision in Bangladesh. *Sustainability*, 10(6), 1831-1850, <https://doi.org/10.3390/su10061831>.
- Whelan, T., Atz, U., Van Holt, T. & Clark, C. (2022). Uncovering the Relationship by Aggregating Evidence from 1,000 Plus Studies Published between 2015–2020. *NYU, ESG and Performance*, [https://www.stern.nyu.edu/sites/default/files/assets/documents/NYU-RAM\\_ESG-Paper\\_2021%20Rev\\_0.pdf](https://www.stern.nyu.edu/sites/default/files/assets/documents/NYU-RAM_ESG-Paper_2021%20Rev_0.pdf) (Accessed: 22.08.2023).

- Yu, S. & Li, Z. (2018). Forecasting Stock Price Index Volatility with LSTM Deep Neural Network. *Recent Developments in Data Science and Business Analytics*, 265–272, [https://doi.org/10.1007/978-3-319-72745-5\\_29](https://doi.org/10.1007/978-3-319-72745-5_29).
- Yu, X. & Xiao, K. (2022). Does ESG Performance Affect Firm Value? Evidence from a New ESG-Scoring Approach for Chinese Enterprises. *Sustainability*, 14(24), 16940, <https://doi.org/10.3390/su142416940>.
- Zhou, D. & Zhou, R. (2021). ESG Performance and Stock Price Volatility in Public Health Crisis: Evidence from COVID-19 Pandemic. *International Journal of Environmental Research and Public Health*, 19(1), 202-217, <https://doi.org/10.3390/ijerph19010202>.
- Zhou, Y., Han, R., Xu, Q., Jiang, Q. & Zhang, W. (2018). Long short-term memory networks for CSI300 volatility prediction with Baidu search volume. *Concurrency and Computation: Practice and Experience*, 31(10), 4721-4728. <https://doi.org/10.1002/cpe.4721>

APPENDIX

Figure 1: Structure of LSTM

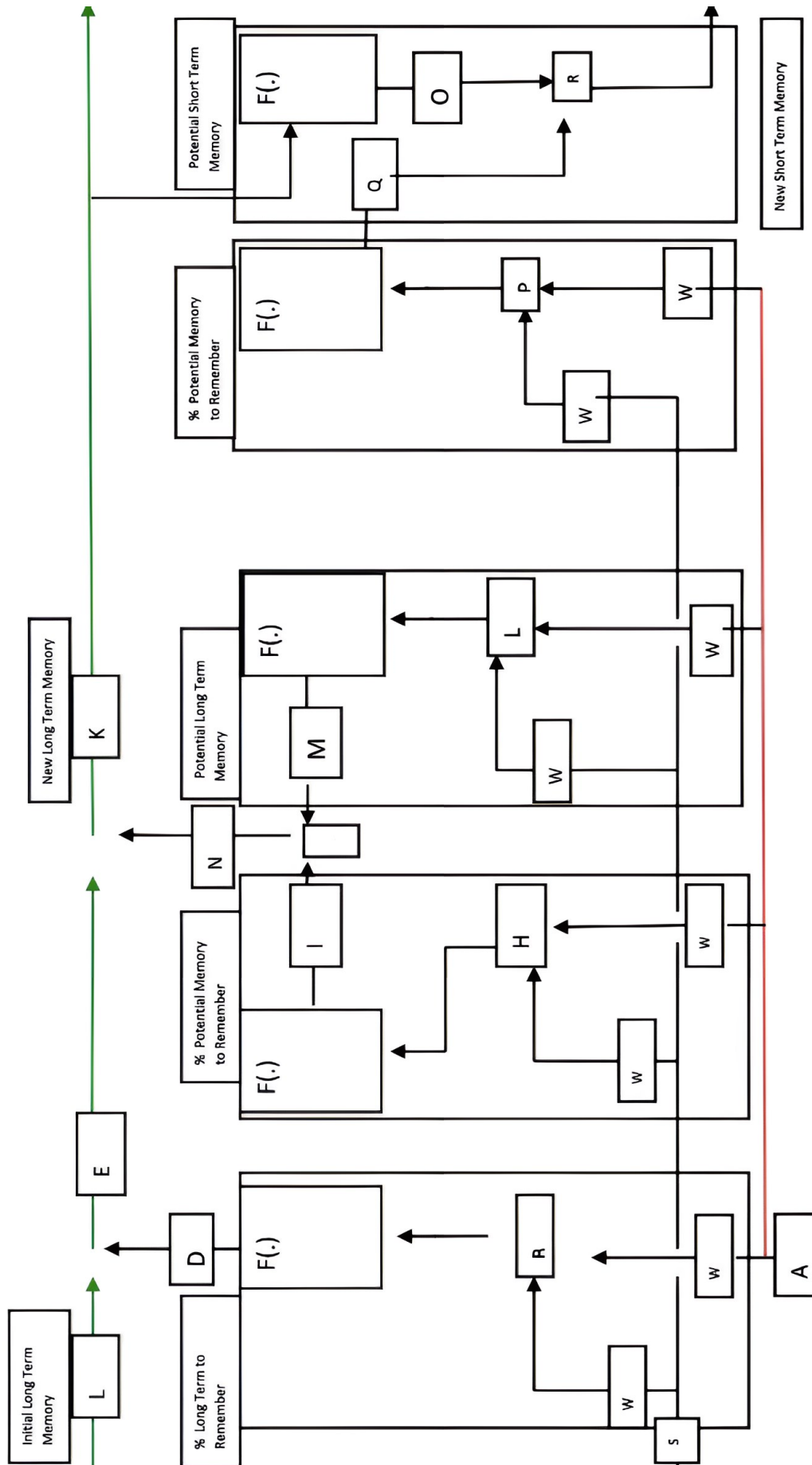

$w$  = weights.  $F(.)$  = Activation function.  $S$  = initial short-term memory.  $A$  = input at time period  $t-k$ .  $R = w(S+A)$   $D = F(R)$   $E = D * L$   $H = w(S+A)$   $I = F(H)$   $M = F(L)$   $N = I * M$   $K = E + N$   $L$  = New long-term memory.  $E = D * L$   $H = w(S+A)$   $I = F(H)$   $M = F(L)$   $N = I * M$   $K = E + N$   $L$  = New long-term memory.  $P = w(S+A)$   $Q = F(P)$   $R = Q * O$   $O$  = The new short-term memory, which now acts as the initial short-term memory for the next unit, or it is the final predicted value if this current unit is last in the unrolling process.

Source: Author's own work.

**Figure 2: Comparing predicted values with the actual values over the test set of data\***

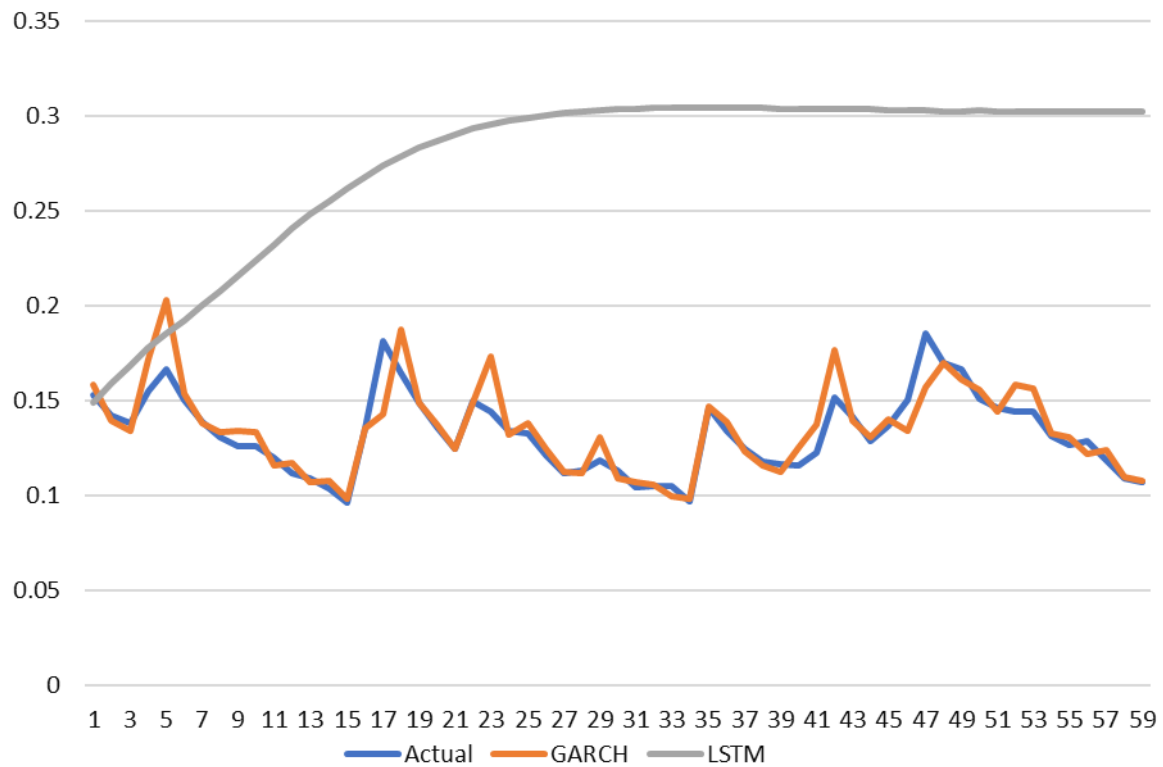

\* The testing data set ranges from 5th January 2023 to 31st March 2023 (frequency = daily)

Source: Author's own work.

**Figure 3: Comparing the predicted values generated from LSTM using default activation function at epoch level 10 with the actual values over the test set of data**

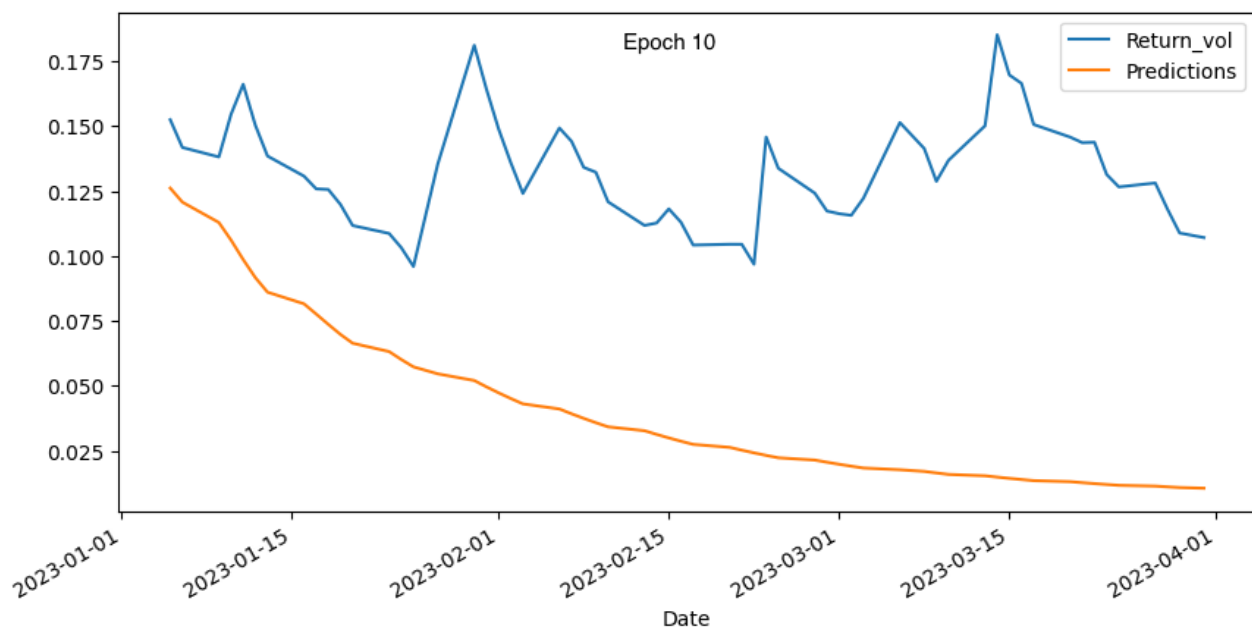

Source: Author's own calculations.

**Figure 4: Comparing the predicted values generated from LSTM using default activation function at epoch level 20 with the actual values over the test set of data**

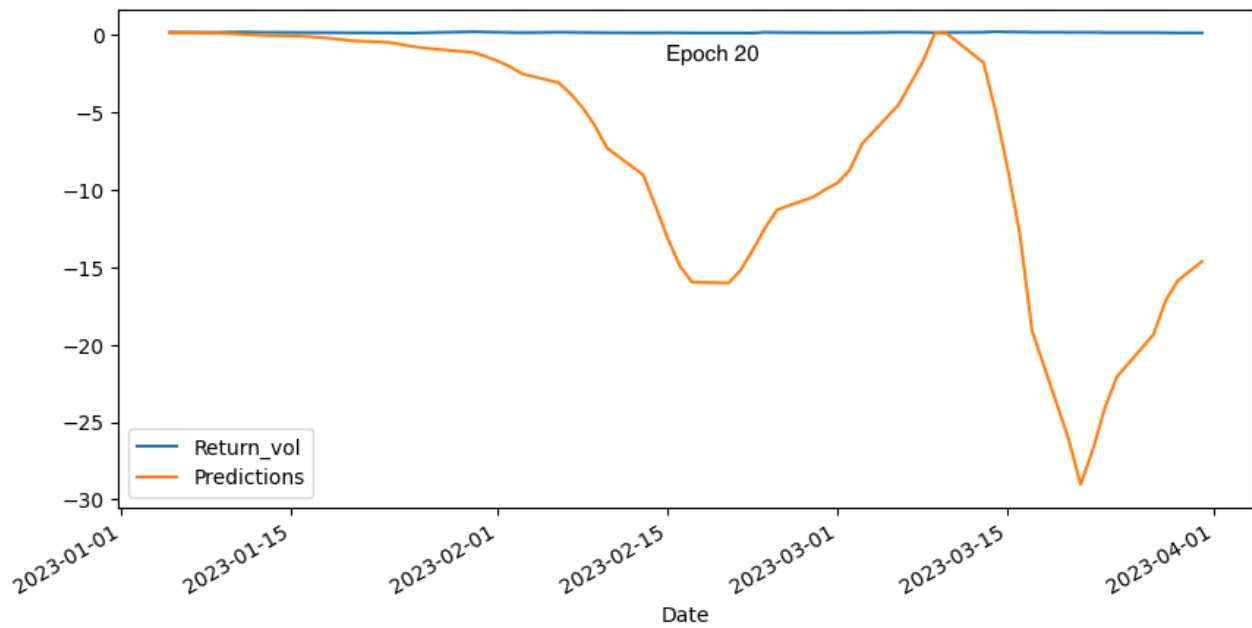

Source: Author's own calculations.

**Figure 5: Comparing the predicted values generated from LSTM using default activation function at epoch level 30 with the actual values over the test set of data**

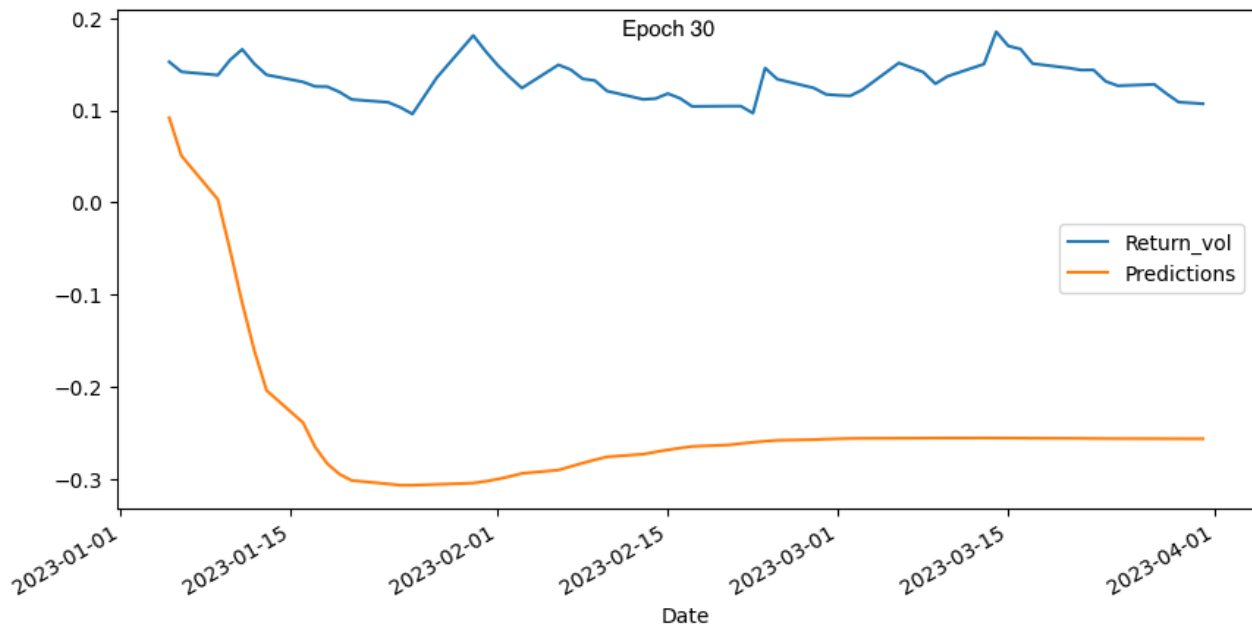

Source: Author's own calculations.

**Figure 6: Comparing the predicted values generated from LSTM using default activation function at epoch level 40 with the actual values over the test set of data**

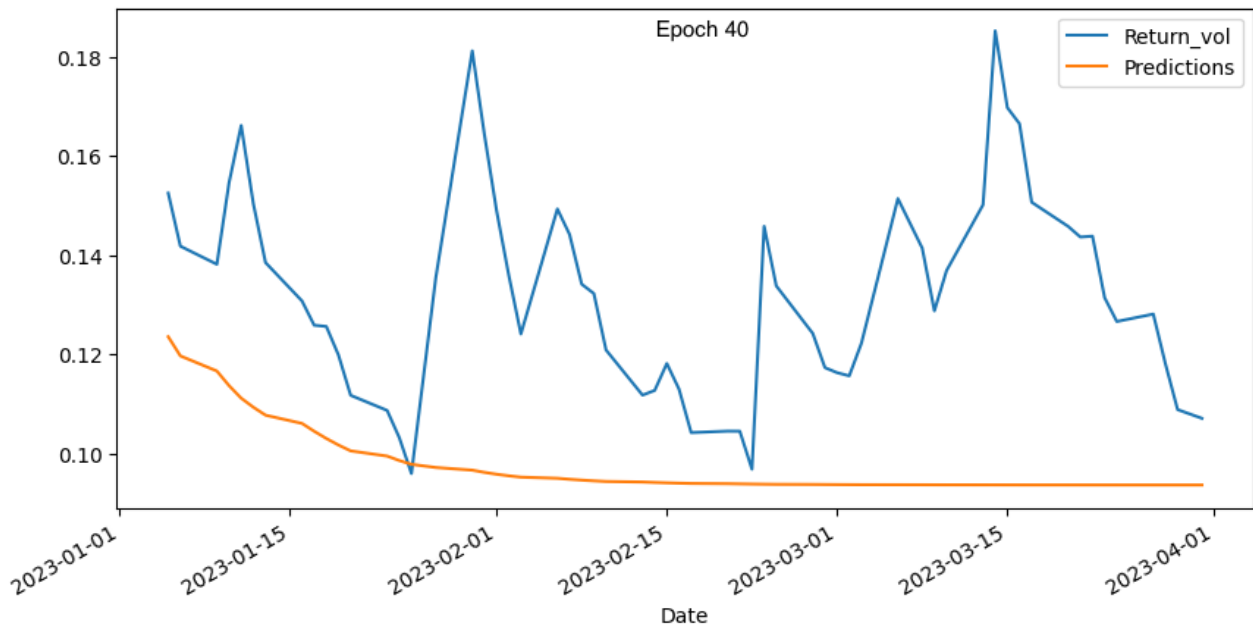

Source: Author's own calculations.

**Figure 7: Comparing the predicted values generated from LSTM using default activation function at epoch level 50 with the actual values over the test set of data**

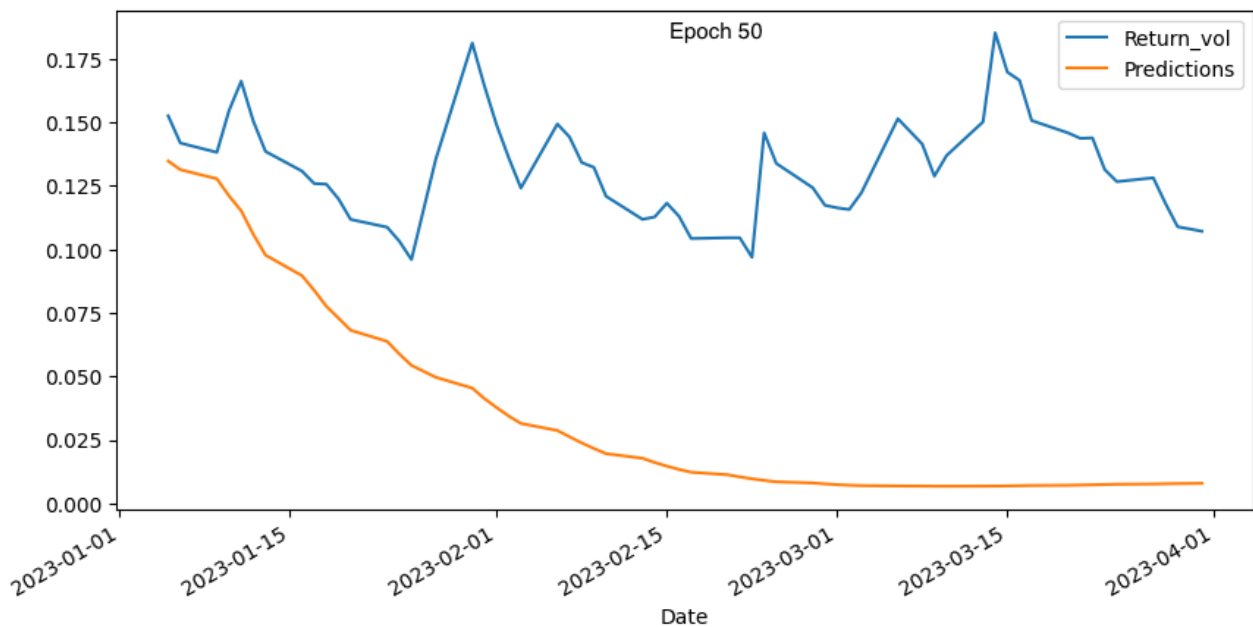

Source: Author's own calculations.

**Figure 8: Comparing the predicted values generated from LSTM using default activation function at epoch level 60 with the actual values over the test set of data**

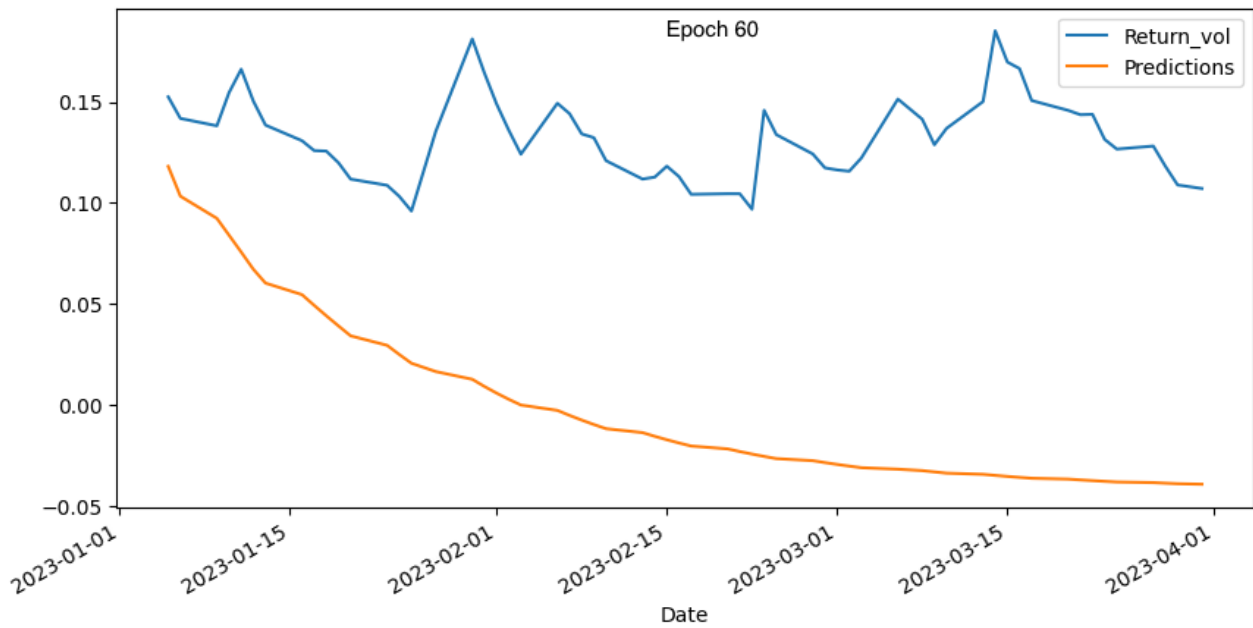

Source: Author's own calculations.

**Figure 9: Comparing the predicted values generated from LSTM using ReLU activation function at epoch level 10 with the actual values over the test set of data**

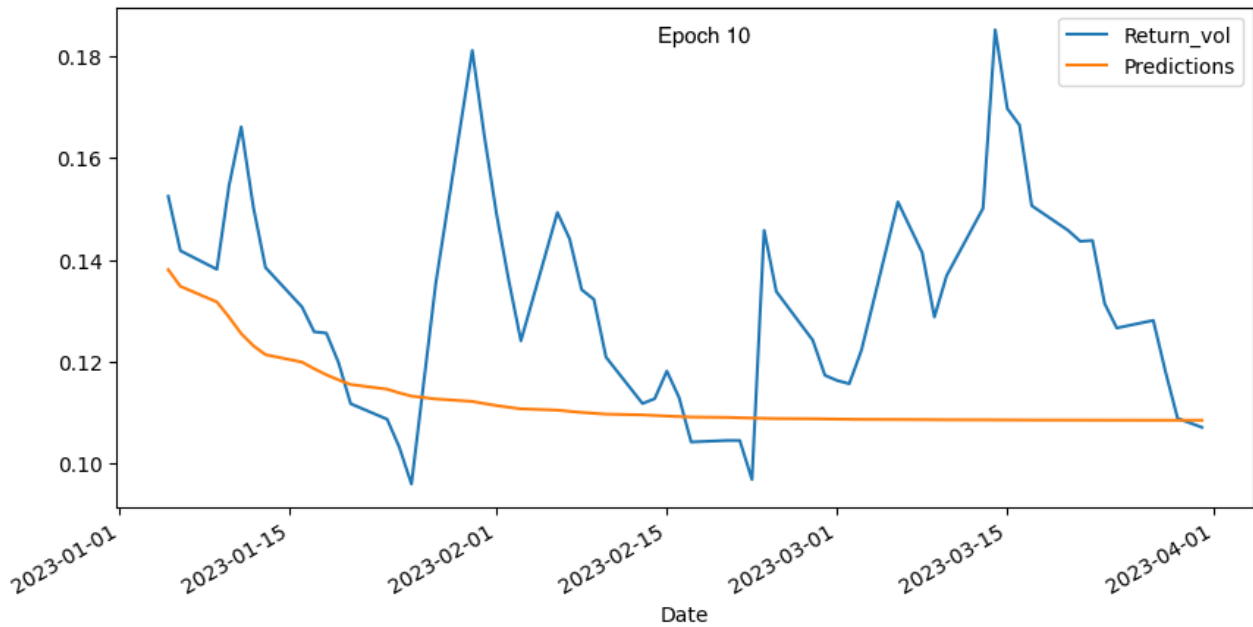

Source: Author's own calculations.

**Figure 10: Comparing the predicted values generated from LSTM using ReLU activation function at epoch level 20 with the actual values over the test set of data**

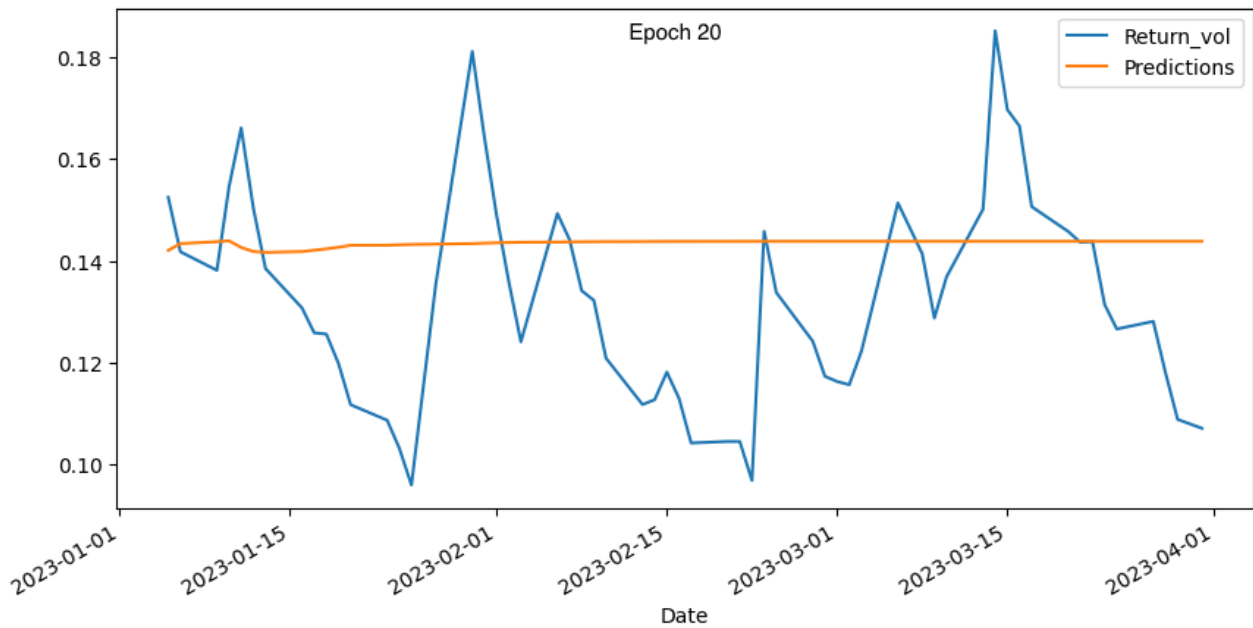

Source: Author's own calculations.

**Figure 11: Comparing the predicted values generated from LSTM using ReLU activation function at epoch level 30 with the actual values over the test set of data**

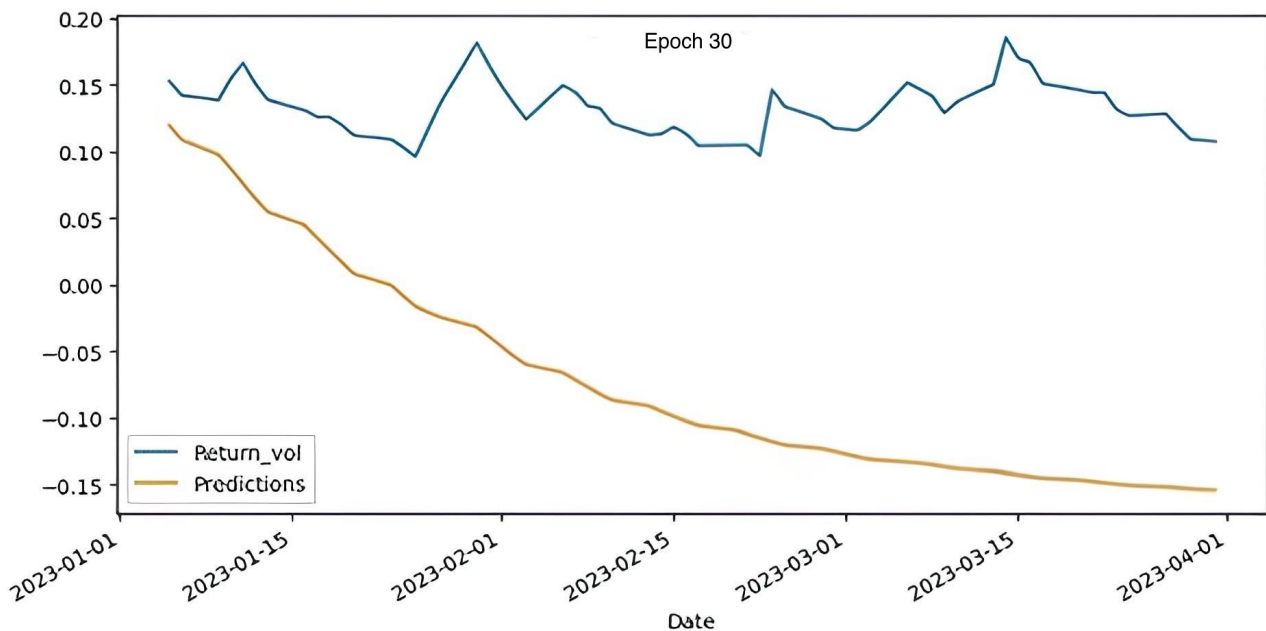

Source: Author's own calculations.

**Figure 12: Comparing the predicted values generated from LSTM using ReLU activation function at epoch level 40 with the actual values over the test set of data**

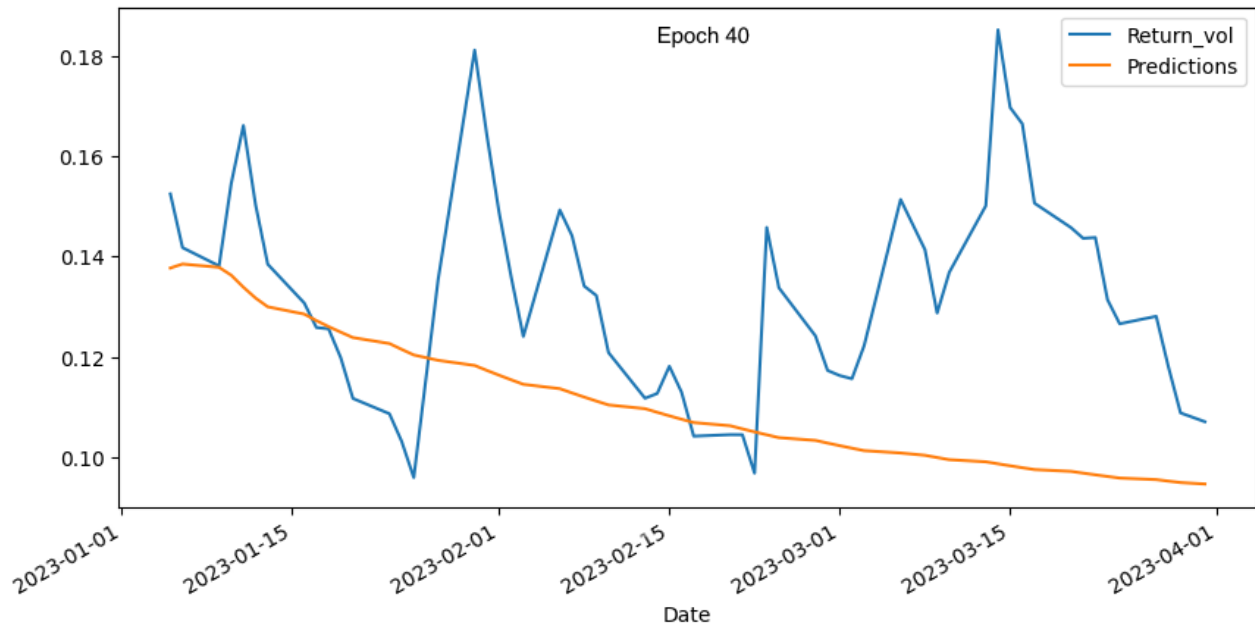

Source: Author's own calculations.

**Figure 13: Comparing the predicted values generated from LSTM using ReLU activation function at epoch level 50 with the actual values over the test set of data**

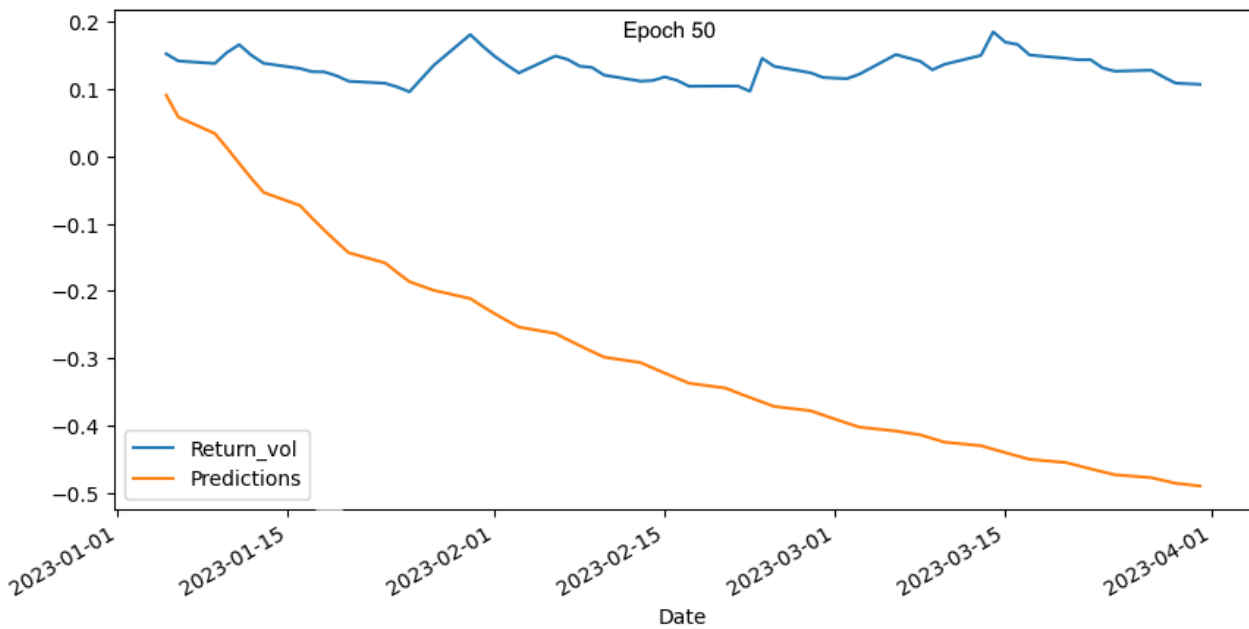

Source: Author's own calculations.

**Figure 14: Comparing the predicted values generated from LSTM using ReLU activation function at epoch level 60 with the actual values over the test set of data**

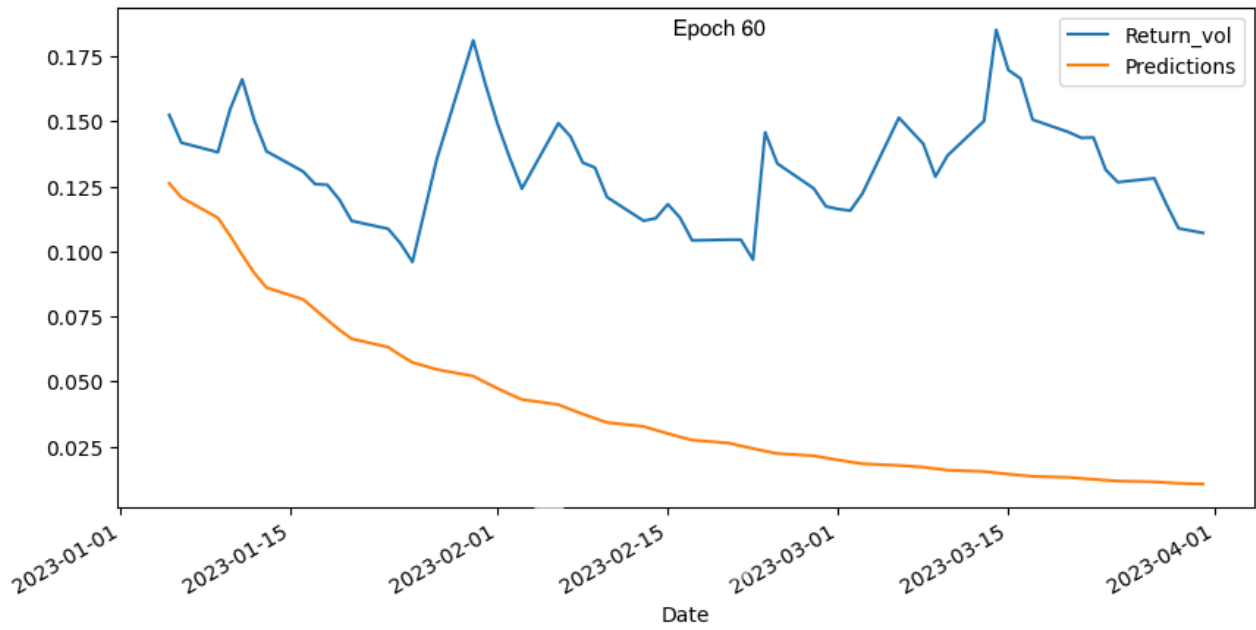

Source: Author's own calculations.